

# 45RFE-HD2-A

## *Reprogramming Kit*™



**Fits: 45RFE - 545RFE - 65RFE - 66RFE & 68RFE  
1999-17 Dodge-Jeep Gas & Diesel.**

**Prevents-Corrects-Reduces  
Rough Lockup, Converter drain back.  
Allows use of Pump Cover with worn TC limit  
bore. HD Accumulator Cover Plate Replacement  
Springs for Pump.**

**Hello Tech:** Don't let the number of pages scare you. We have enclosed a lot of helpful information that is model specific to help prevent mistakes from being made during repair/installation. The actual installation of the kit parts is easy.



***Short, clean shifts  
you'll just love!***



**Mr. Shift**

**Hello Mechanic:** Remove transducer **before** cleaning or washing the trans. It's a good idea to replace this sensor on every overhaul.



**If Trans Is In Vehicle:**  
Skip this page AND page 2, 3 or 4.  
(Depending on Model.)

### Step 1

Remove TC Limit and ID which Type Valve the pump has:  
**IF** pump has a **TYPE 1 Valve**, use **NEW Type 1 Bushing!**

**IF** pump has a **TYPE 2 Valve**, use **NEW Type 2 Bushing!**

**Please use care when matching the parts!**

V-Notch Retainer must install below flush on pump. Grind the top of retainer if needed.

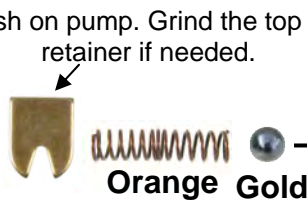

New Type 1 Bushing

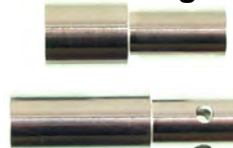

New Type 2 Bushing

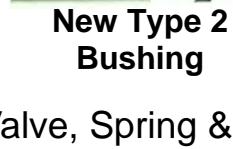

ID Original Valve Type:



Type 1  
or  
Type 2

TC Limit

### Step 2

Discard original TC Limit Valve, Spring & Retainer.  
Install new **Bushing**, **GOLD** ball, **ORANGE** Spring & **V-Notch Retainer**. It is correctly installed when the bushing is inserted far enough to install the retainer. Bushing does not go any deeper.

**Regardless** of the amount of **BORE WEAR** this system **WORKS** perfectly!  
**Install it and forget it!**

Tech Tip: Over-night drain-back can be caused by this ball-check air bleed leaking. (Visible with pan removed - Not found on all pumps.) OK to plug if leaking. No threads in hole? No ball-check was used. Do not swap pump plates!

### Step 3

Install new slotted **Retainer** and three **PLAIN** Springs into open end of Accum Piston. No need to disassemble inner retainer or inner valve assy.

New Slotted Retainer

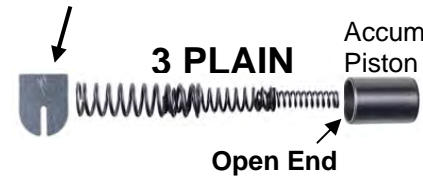

3 PLAIN

Accum Piston

Open End

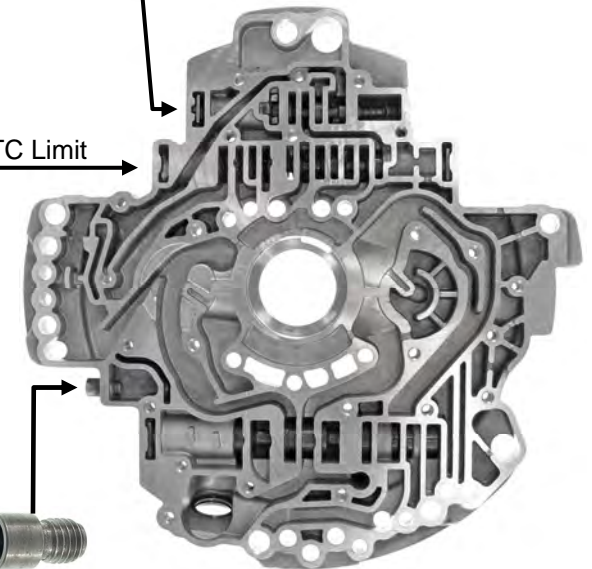

Pump Cover

# ALL 45/545/65RFE & 2012-13 66RFE Input Drum:

## Heavy Duty Underdrive Snap Ring

Replaces tapered ring that breaks and pops out.

Install the **Snap Ring** on top of underdrive pressure plate. Using screwdriver, *firmly* seat **Snap Ring** into groove in six places. Don't worry, It's supposed to be a **TIGHT** fit.

## Heads Up! 45/545/65RFE & 2012-2013 66RFE OD Clutches & Steels are thicker than UD and Rev. Pay attention!

UD FRICTION .075	OD FRICTION .090	REV FRICTION .075
UD STEEL .068	OD STEEL .087	REV STEEL .068

2007up UD/OD Press Plate has approx .065 offset on OD side p/n 68009902AC →  
 1999-06 UD/OD Press Plate has approx .021 offset on OD side p/n 68009108AA →

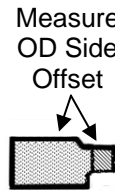

Drum ID: Measure from top of drum to top of .061 flat snap ring: 2007up = 1.960 / 1999-06 = 1.907

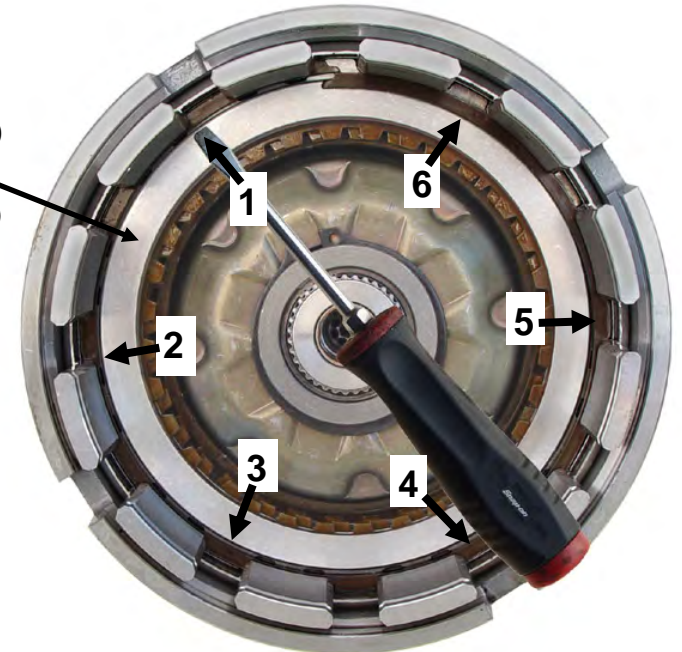

## Input Drum--Cutaway Side View

Clutch Packs:  
Rev--OD--UD

Pressure Plates: UD--OD--Rev  
 Snap Rings: Flat, Flat, Waved

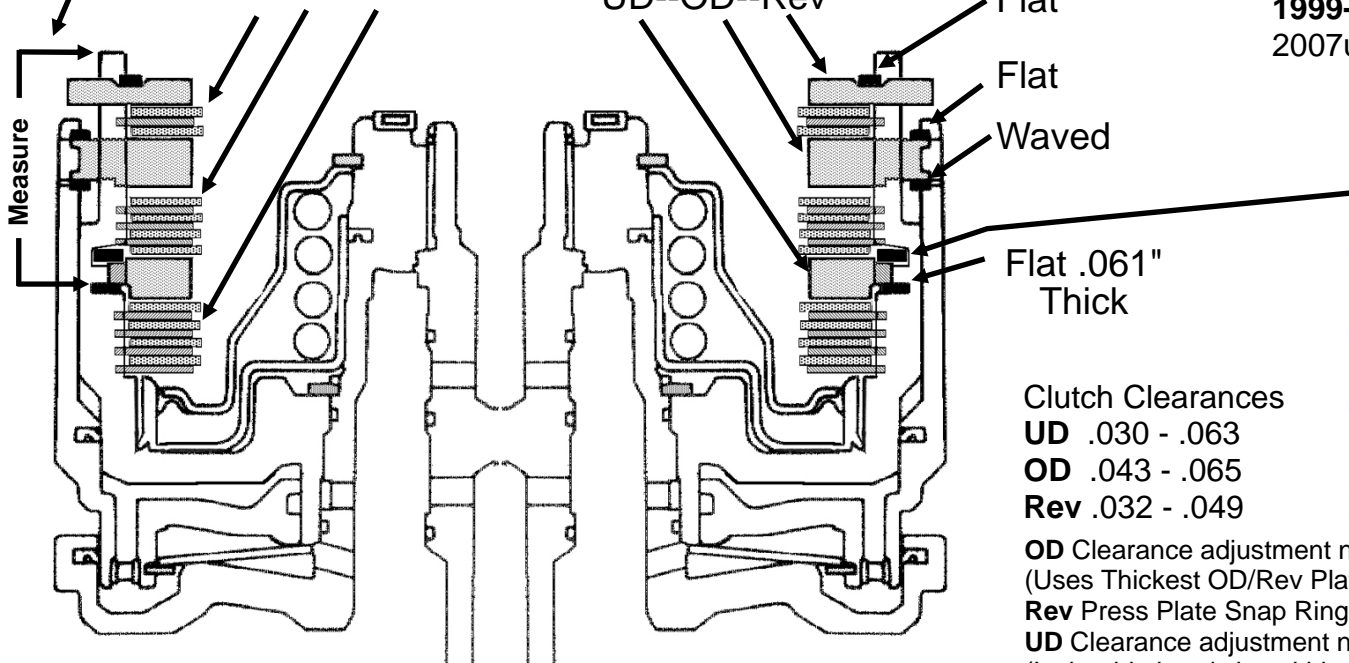

**Note:** 2012-13 66RFE Trans's may have been repaired with 2014up Input drum parts, see pg3.  
 1999-06 Trans's may have been repaired with 2007up Input drums. Measure drum to ID.

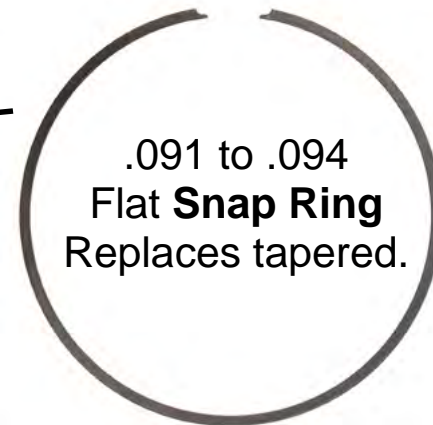

Clutch Clearances  
 UD .030 - .063  
 OD .043 - .065  
 Rev .032 - .049

OD Clearance adjustment not necessary **WITH** correct parts usage.  
 (Uses Thickest OD/Rev Plate p/n 68323984AA 9.62-9.85mm)  
 Rev Press Plate Snap Ring Selective to adjust Rev Clearance.  
 UD Clearance adjustment not necessary **WITH** correct parts usage.  
 (It should already be within spec's.)

# 2014up 66RFE Input Drum:

## Heavy Duty Underdrive Snap Ring

Replaces tapered ring that breaks and pops out.

Install the **Snap Ring** on top of underdrive pressure plate. Using screwdriver, *firmly* seat **Snap Ring** into groove in six places. Don't worry, It's supposed to be a **TIGHT** fit.

**Heads Up!** 2014up 66RFE OD Clutches are **thinner** & the Steels are **thicker** than UD and Rev. Pay attention!

The UD/OD & OD/Rev Pressure plates were also changed at the same time from the previous 2012 & 2013 models.

UD FRICTION .075	OD FRICTION .070	REV FRICTION .075
UD STEEL .068	OD STEEL .120	REV STEEL .068

UD/OD Press Plate has approx .081 offset on OD side p/n 68186197AA

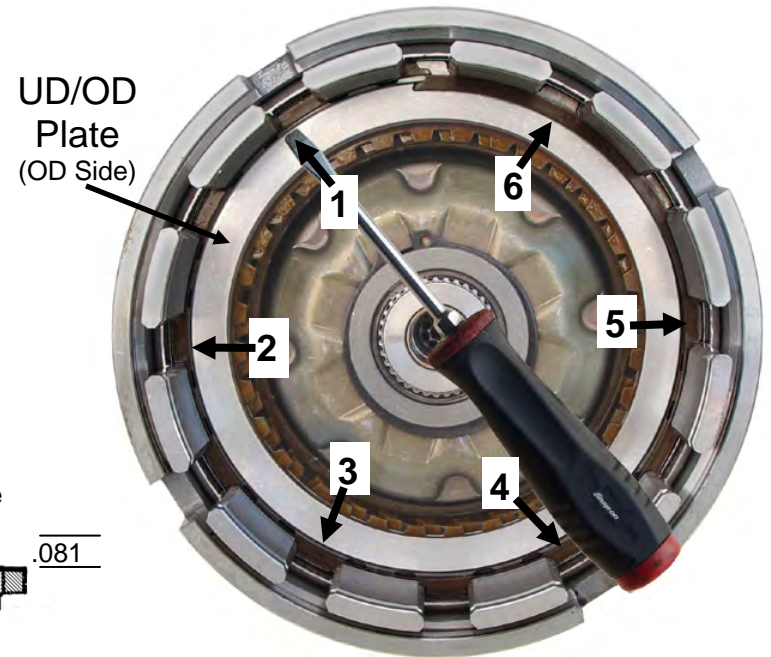
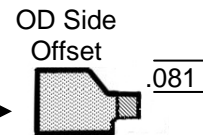

## Input Drum--Cutaway Side View

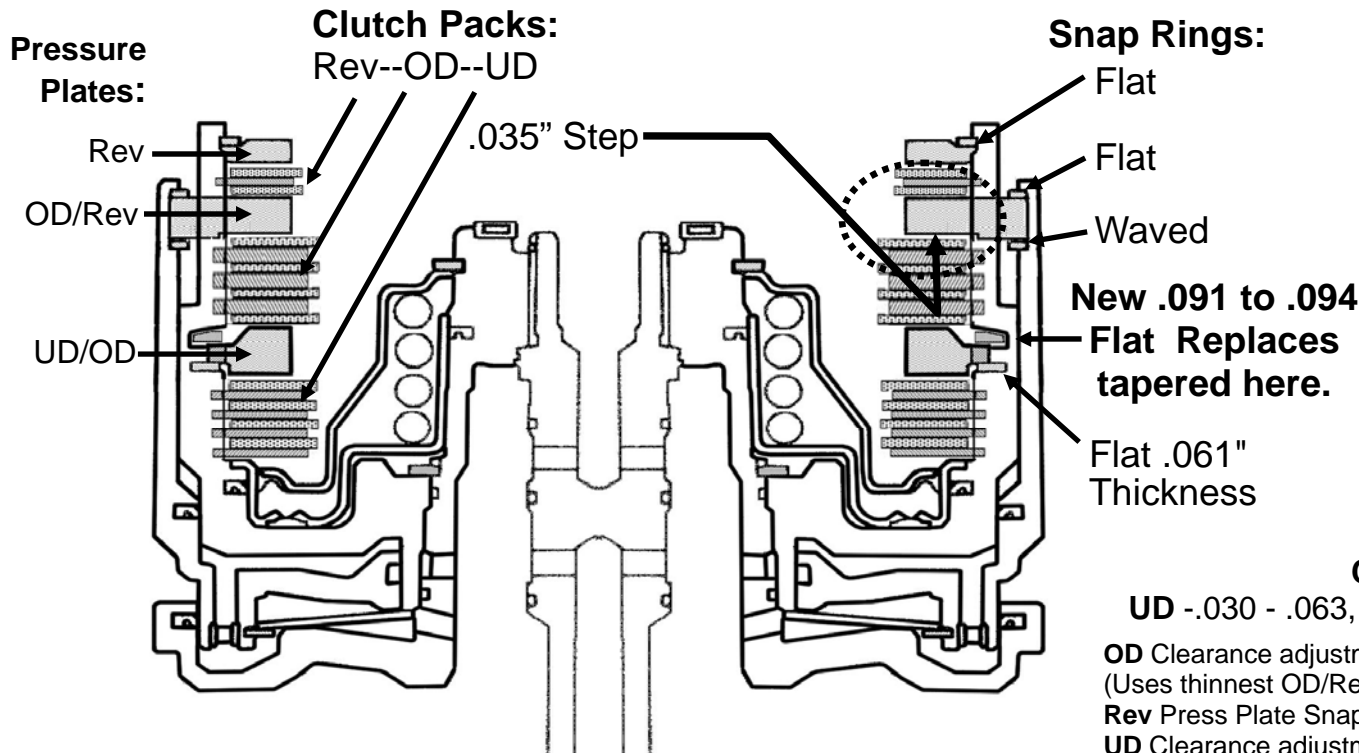

## Working on a 2012-13 66RFE?

P/N 68321415AB is a service package that if used **completely** will update a 2012-13 66RFE to 2014up spec's. Approx \$185.00 Comes with UD, OD, Rev clutches and steels. UD/OD pressure plate, OD/Rev pressure plate, Input drum seals, UD apply piston, UD balance piston, tapered snap ring & 3 selective Rev Clutch Snap rings. This package will service all 66RFE's 2012 & up.

### Clutch Clearances

**UD** -.030 - .063, **OD** -.030 - .063, **Rev** -.023 - .058

OD Clearance adjustment not necessary **WITH** correct parts usage. (Uses thinnest OD/Rev Plate p/n 52119929AB 8.79-9.01mm)

Rev Press Plate Snap Ring Selective to adjust **Rev Clearance**.

UD Clearance adjustment not necessary **WITH** correct parts usage. (It should already be within spec's.)

# 68RFE: Input drums use one sided clutches UD & OD

**UD & OD, clutch friction surfaces face UP!**

**UD clutch** has ten .058 thick frictions. **OD clutch** has twelve .050 thick frictions.

**Reverse clutch** has 2 double sided frictions & 1 steel.

**UD stack-** Start with .058 friction plate with external lugs, alternate with internal lug plates. The stack will end with a friction plate with internal lugs. Install thin snap-ring, UD/OD Pressure plate then replace beveled snap-ring with new .091 to .094 flat snap-ring.

**OD stack-** Start with .050 friction plate with external lugs, alternate with internal lug plates. The stack will end with a friction plate with internal lugs. Install waved snap-ring, OD/Rev Pressure Plate **\*If plate has a step, (ID #'s 1 & 2) the stepped side faces down**, then install flat snap-ring.

**Rev stack-** Start with double sided friction, steel, double sided friction, Pressure plate and flat snap-ring.

## OD/Rev Pressure Plate P/N's

52119929AB 8.79-9.01mm

52119930AB 9.22-9.45mm

68323984AA 9.62-9.85mm

OD/Rev Pressure Plate:

\*If plate has a step, the stepped side faces down!

**Plate ID:** "1", "2" & no code.

No code is flat both sides.

UD/OD Pressure Plate

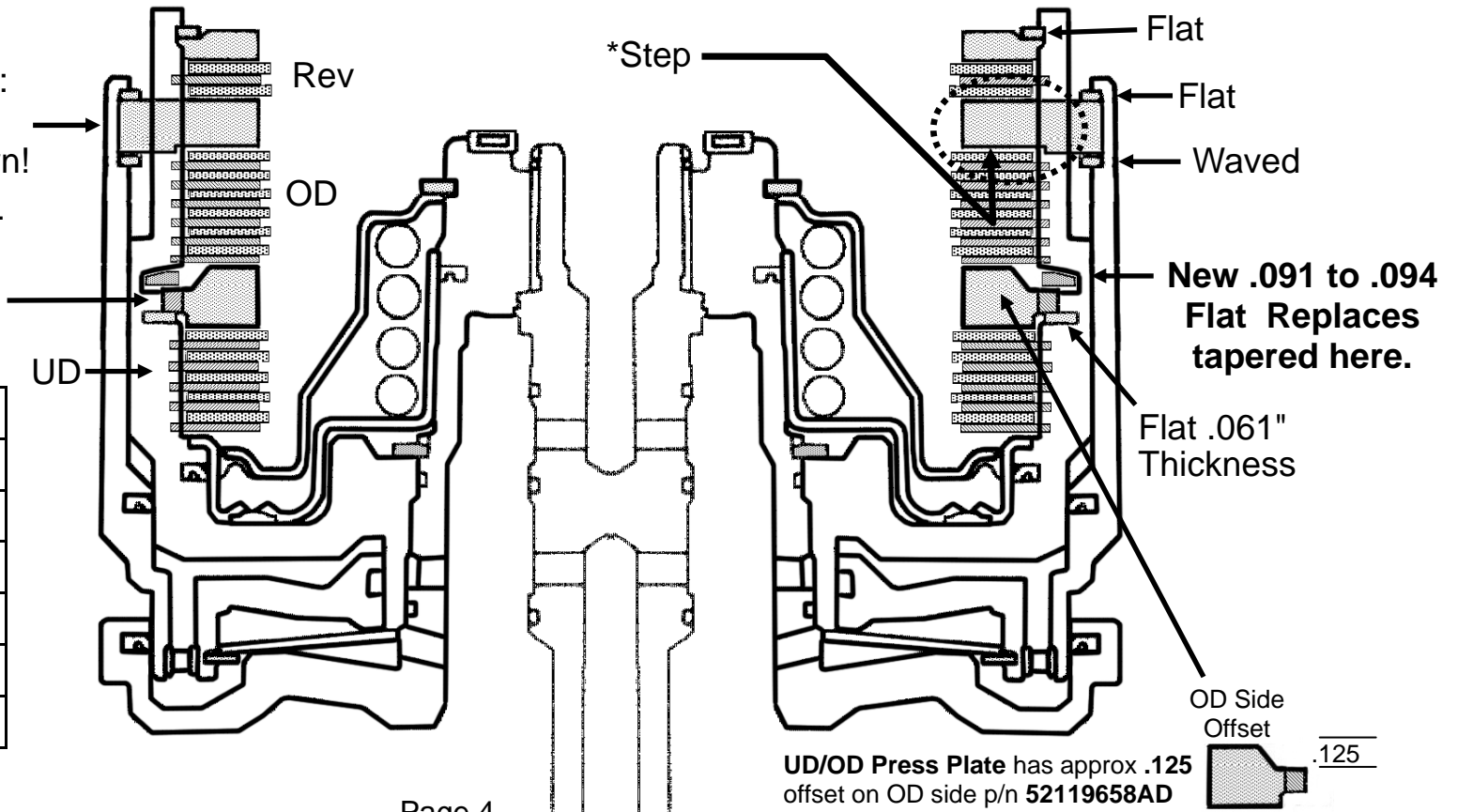

68 RFE Clutch Clearance	
UD	.038 - .068
OD	.030 - .063
Rev	.032 - .049
L/R	.045 - .081
4C	.030 - .053
2C	.038 - .066

UD/OD Press Plate has approx .125 offset on OD side p/n 52119658AD

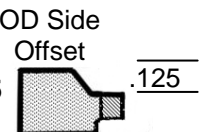

# 45/545/65&66RFE Valve Body's

1. **Aluminum** Pistons: Install wire expander and new ring into inner ring groove as shown.  
**Plastic** Pistons: Skip this step.

© 7 or 5 Checkballs

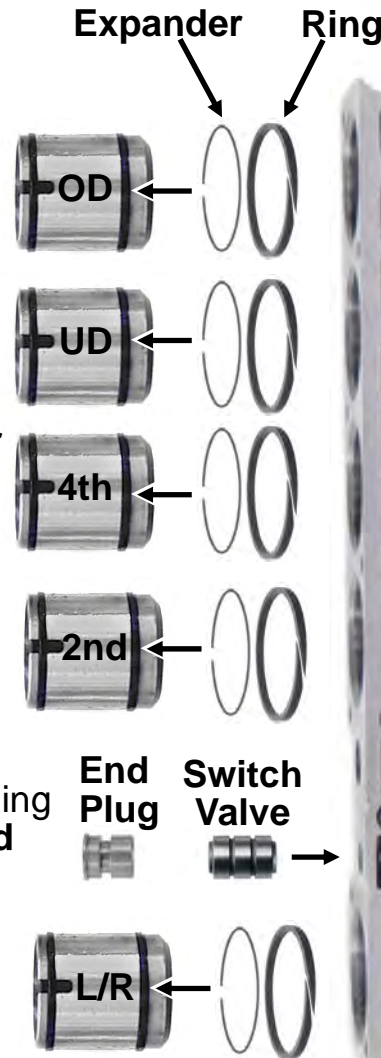
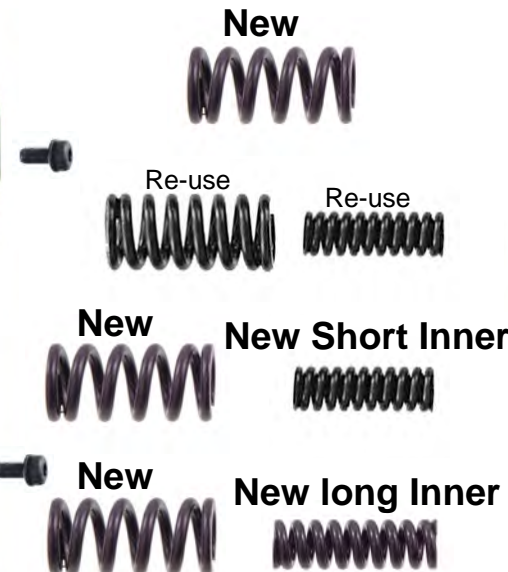
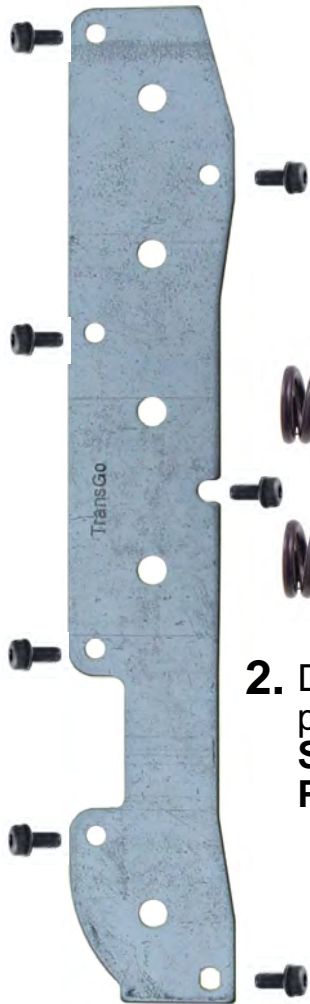

## Hold it!

Some late VB's don't use these 2 check balls & the VB plate will have 1 hole over these 2 tub locations. Earlier models have 2 holes in the plate & use a ball in each location! Be sure this is right or you'll be making clutch toast for lunch!

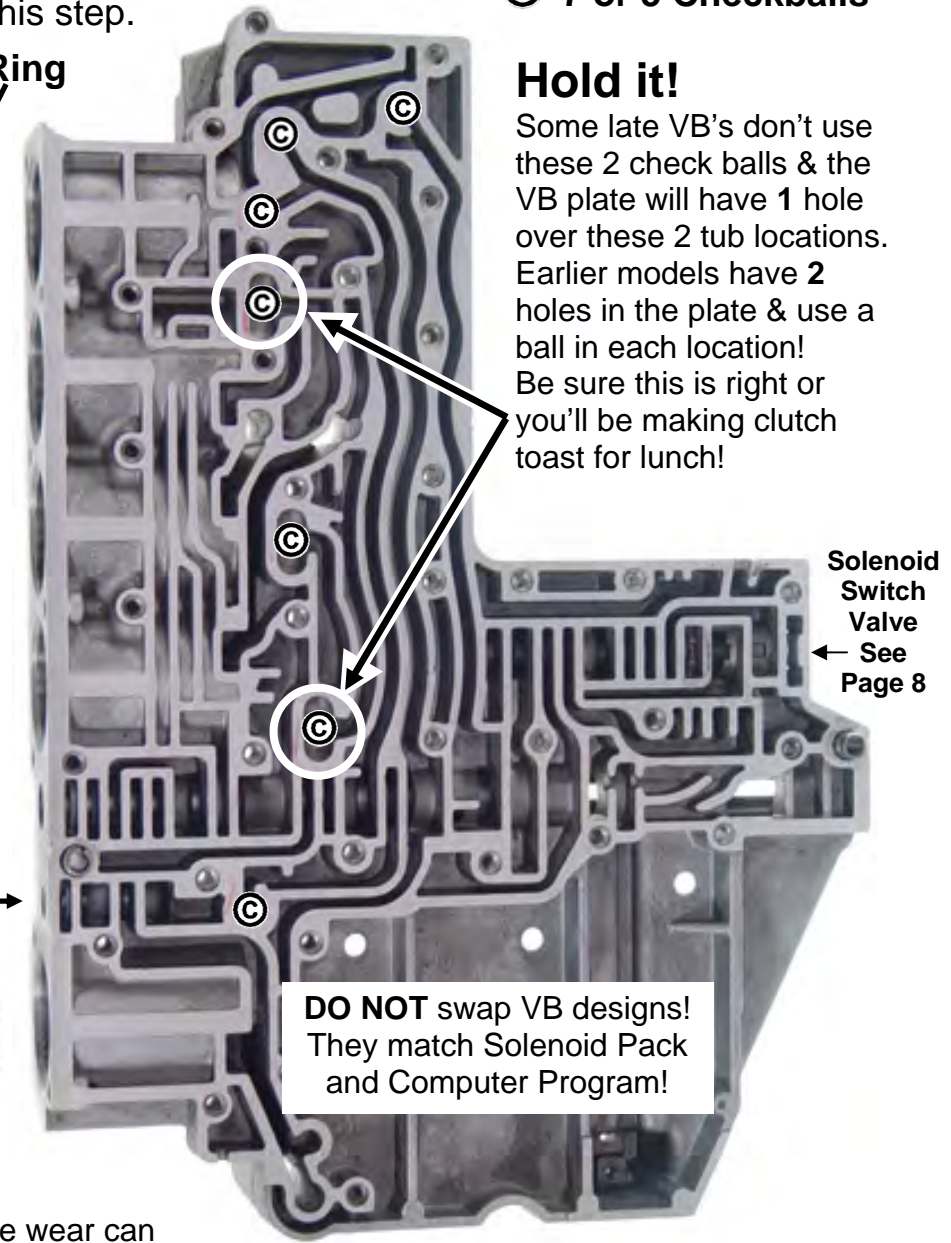

**DO NOT** swap VB designs!  
They match Solenoid Pack  
and Computer Program!

2. Discard original valve and plug. Install new self cleaning **Switch Valve** and new **End Plug** furnished.

3. Install **NEW HD Cover.**

**Tech Tip:** Solenoid Switch Valve bore wear can cause a variety of codes and failures. See page 8.

# 68RFE Valve Body

Was OD Clutch Damaged?  
Vehicle has High mileage?

See pages 7 & 8 first!

1. **Aluminum** Pistons: Install wire expander and new ring into inner ring groove as shown.

**Plastic** Pistons: Skip this step.

© 7 or 5 Checkballs

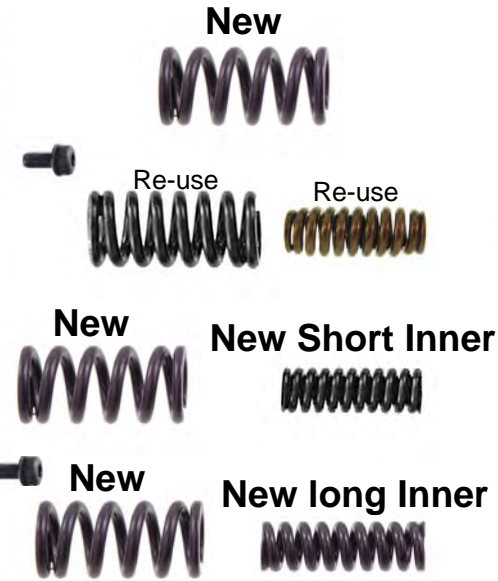

2. Discard original valve and plug. Install new self cleaning **Switch Valve** and new **End Plug** furnished.

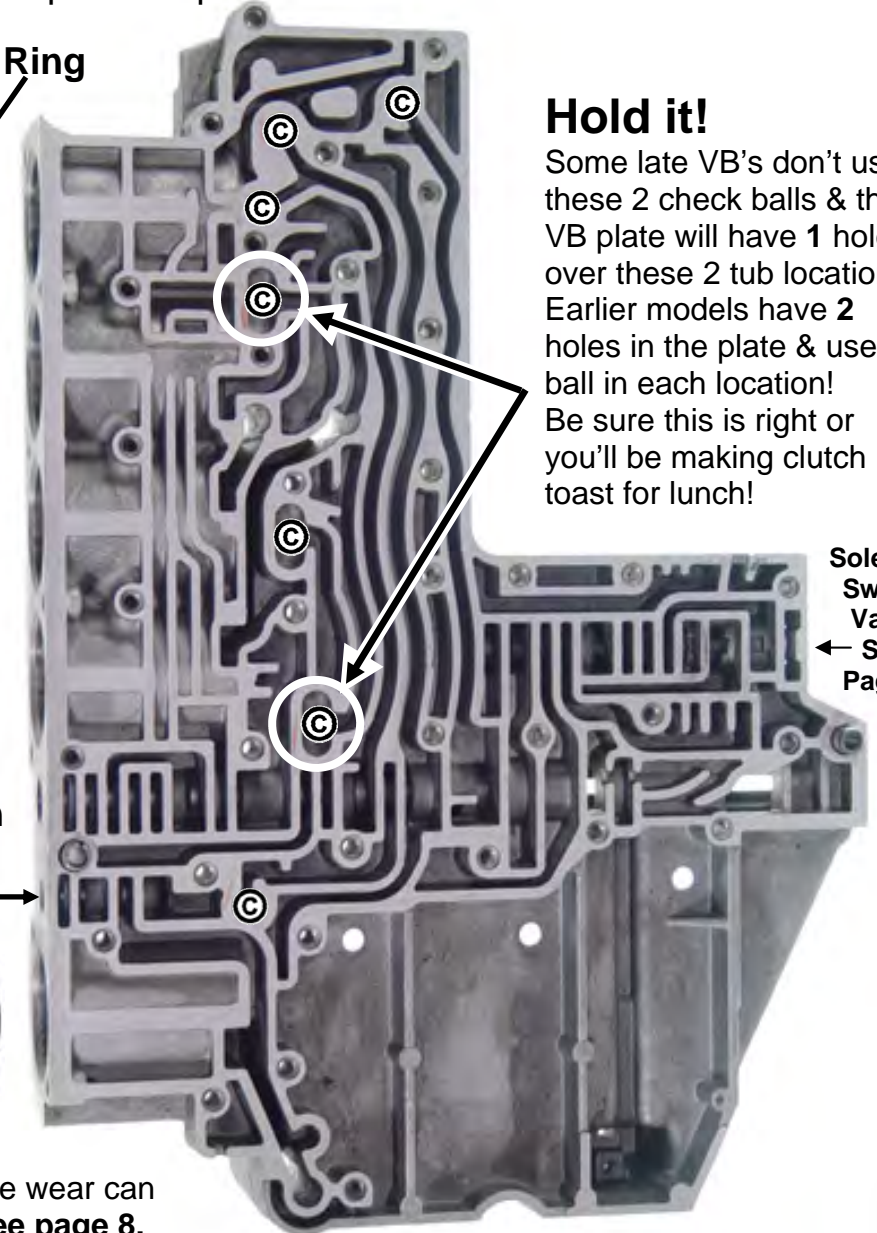
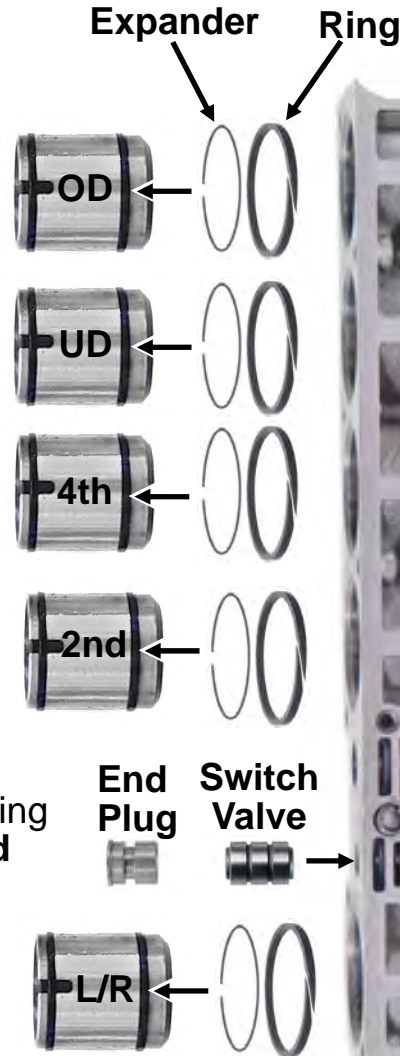
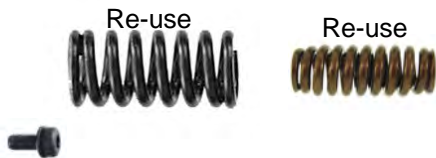

**Hold it!**

Some late VB's don't use these 2 check balls & the VB plate will have 1 hole over these 2 tub locations. Earlier models have 2 holes in the plate & use a ball in each location! Be sure this is right or you'll be making clutch toast for lunch!

Solenoid Switch Valve  
← See Page 8

3. Install **NEW HD Cover.**

**Tech Tip:** Solenoid Switch Valve bore wear can cause a variety of codes and failures. See page 8.

# 68RFE: Repeated OD Clutch Failure due to Valve Body Erosion Cross Leaks!

**WATCH OUT FOR THIS**  
on **HARD** working or  
**HIGH** mileage 7 Ball  
68RFE Valve Bodies!

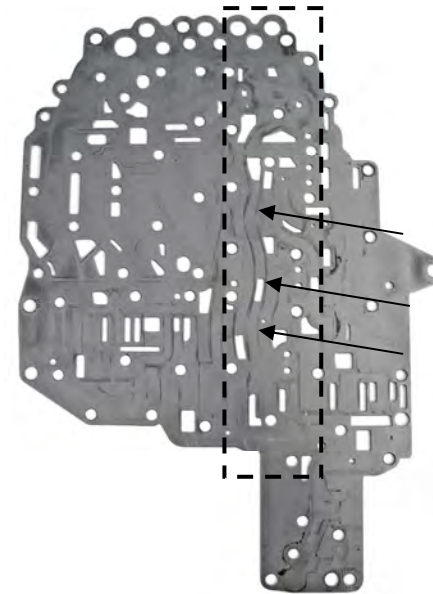
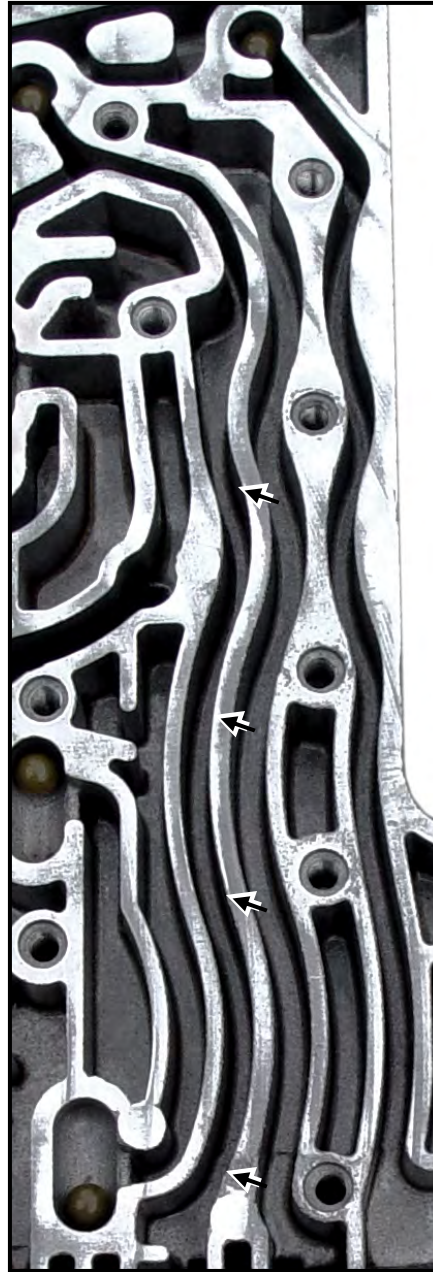

Pressure, time & heat induce flexing of the channel walls. This movement scrubs the separator plate (leaving a mark) and erodes the aluminum casting causing cross leaks. Usually seen in high mileage 68RFE Diesels due to higher pressure and heat. Repeated OD Clutch Failure is common.

This condition is not easily solved by surfacing the VB. It is recommended for long term durability to **replace the VB**. 45/5-45RFE VB's have been used to replace 68RFE VB's as long as you swap over the accumulator springs, the TRS plate & Solenoid Pack. 5 & 7 Ball VB's **Do Not** Interchange!

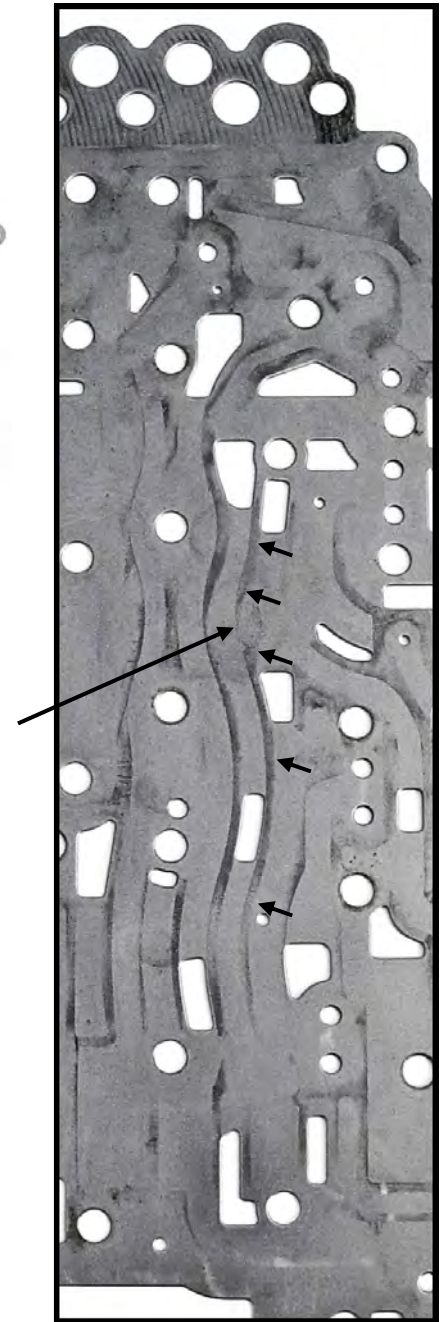



# Swapping out a valve body? Move these 3 Items from the original valve body over to the replacement VB!

## Solenoid Switch Valve Bore Worn?

### What are the risks?

#### May set following codes:

Solenoid switch valve latched in L/R,  
Solenoid switch valve latched in TCC,  
L/R pressure switch rational or circuit error.

#### Can also cause:

OD clutch failure, Kills engine at a stop, TCC  
Slip and/or TCC control stuck off or on.

Why leave it to chance? Even if it didn't come  
in with these issues, with high mileage or lots  
of around town driving it's just a matter of  
time. Order what you need to **Fix it now!**

Measure Valve diameter as shown.

**.420" Dia.** order p/n: **RFE-SV420-WT**

**.453" Dia.** order p/n: **RFE-SV453-WT**

Parts only refills are also available.



Measure Diameter Here .420in. or .453in.

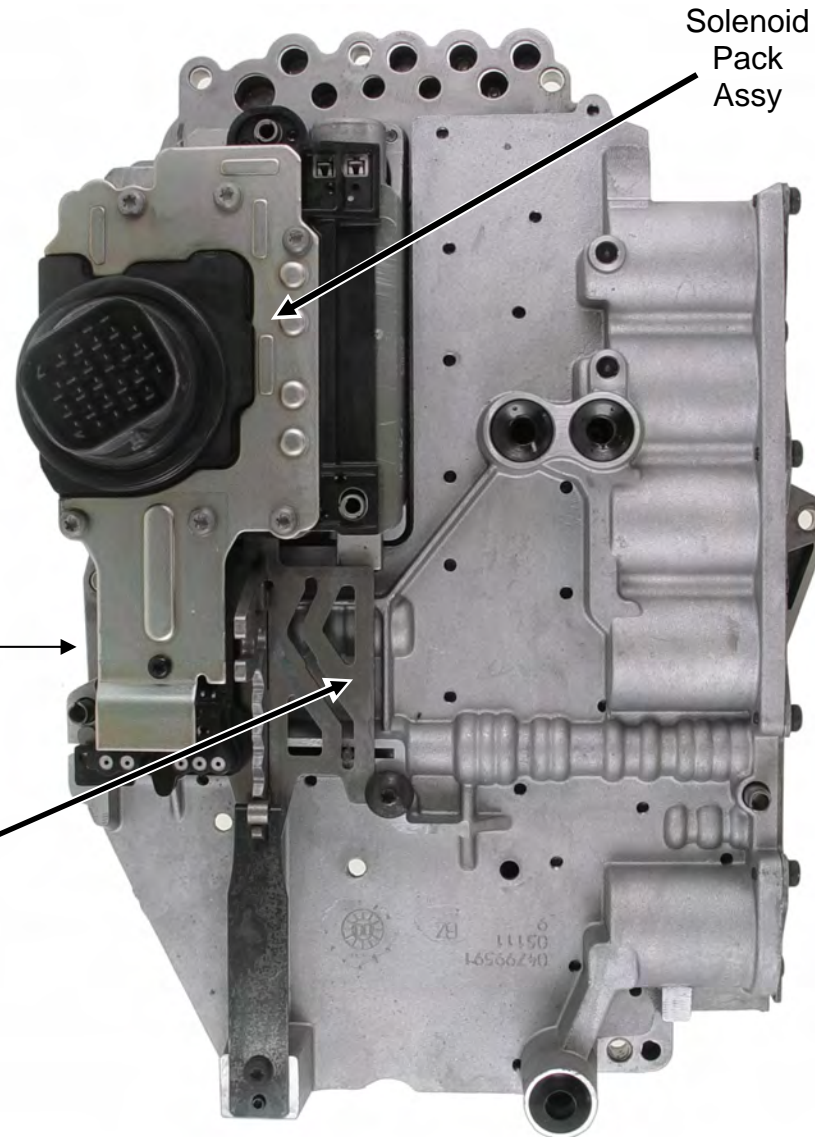

Solenoid  
Pack  
Assy

Accumulator  
Springs

Range Sensor  
Plate

## Hold it!

If swapping VB's, YOU MUST use  
a VB that has the SAME number  
of check balls as the original VB.  
(See page 5 or 6)

## 05 Up Skip this page !!

If using aftermarket power programmer with transmission modifications, *All years.*

## Skip this page !!

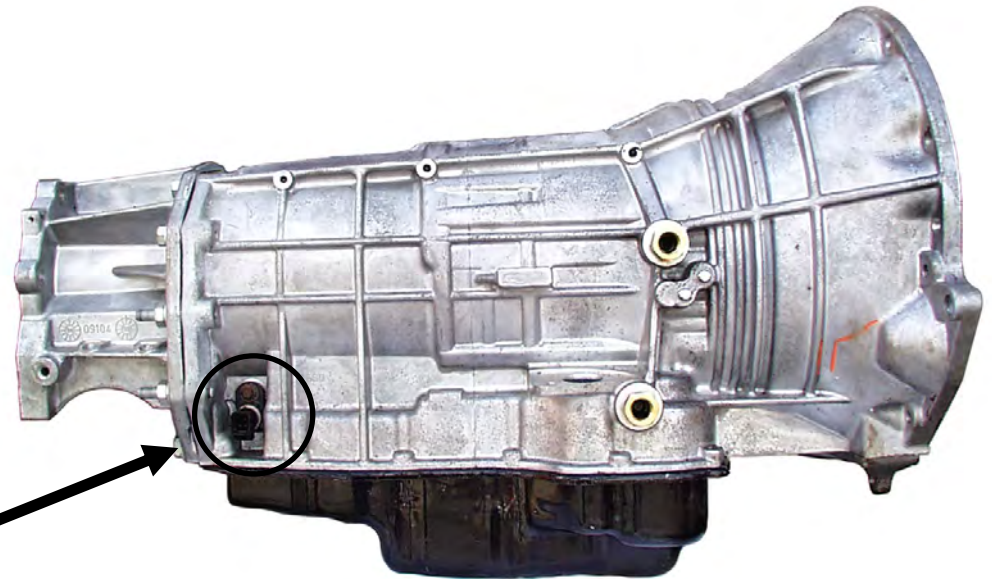
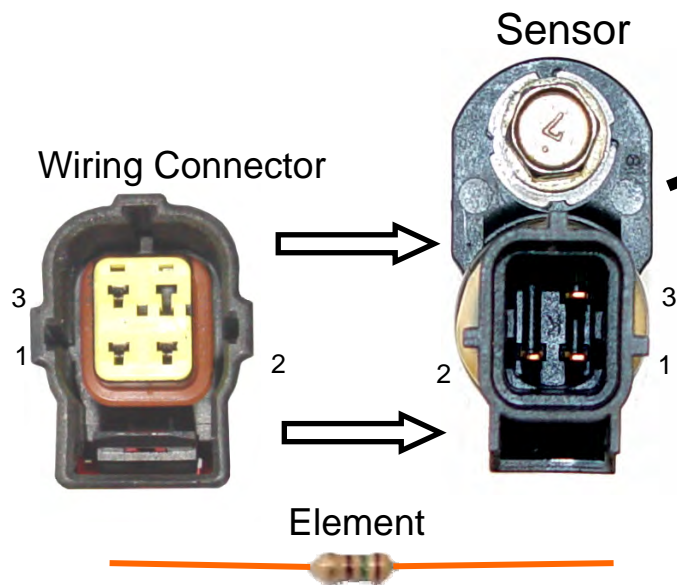

1. Slide insulation away from connector about 1-1/2".
2. Strip the insulation for about 1/4" on wire 1 and 3.
3. Solder one end of element to wire 1 and the other end to 3. Slide up the insulation and tape it shut.

Thanks for Listening, The Tech Team

